



Ottawa 60

DOT/EPA Certified

Standard Specifications

6 X 4 YARD TRACTOR

STANDARD FEATURES

- Cummins ISB-02 200 HP @ 2300 RPM 520 lb/ft torque @1600 RPM certified turbo diesel with primary fuel filter
- Allison 3000RDS Transmission (4 speed)
- Front Axle: Meritor FF-961, 12,000 lb
- Rear Axle: Meritor RT-40-145 7.17:1 Ridewell dynalastic Suspension, 48,000 lb. rating
- 146" Wheelbase with "L" reinforcement
- Fifth wheel: Holland FW-3500, 70,000 lb rating
- Fifth wheel lift cylinders: 5" diameter
- Tires 11R22.5 Steel belted radials 14PR
- Wheels 22.5" X 8.25" 285 mm hub piloted, 10 hole steel disc
- Vertical exhaust system with heat shield
- Air cleaner, frontal inlet
- Back-up light, stop and turn signals
- Mud-flaps rear spring loaded
- Battery box with step 16" width
- Cab side vent
- Drive shaft Spicer 1710 series
- Approximate Vehicle Weight 18,000 lbs.
- GCWR 80,000 Lbs

TRAILER EQUIPMENT

- Two (2) color coded, coiled air lines with glad hand receivers, 7 wire female receptacle at rear of cab, 7 wire coiled trailer light cable

STEERING

- Gearbox type integral power steering with mechanical back up
- Constant running PTO/pump with priority steering circuit

CAB FEATURES

- Cab air ride, 3-point mount suspension
- Cab with flat roof: 50" X 65" welded steel and driver's side door which has a full length piano hinge and an aluminum sliding rear door
- Cab insulation, for thermal protection and noise abatement
- Cab tilt: Electric 45° with 90° tilt capability
- Platform, rear of cab
- Air Ride Seat with isolator
- Seat belt with 2-point mount
- Tinted glass all windows
- 40,000 BTU fresh air heater/defroster
- West coast 16" X 7" mirrors
- See through sun visor
- ICC light package
- **Cab gauges:**
Volt meter, oil pressure, water temperature, fuel level, air pressure, speedometer and 5-digit hour-meter
- **Cab controls:**
Accelerator, tractor/trailer brakes, gear selector, fifth wheel elevation, steering wheel 18" soft touch, dash light controls, turn signals, electric horn, heater defroster, electric windshield washer, electric windshield wiper control, door locks, headlights, side and front clearance lights, inter axle lock, rear flood light upper right side, 5th wheel unlatch

WARNING DEVICES

- Low air pressure light and alarm
- Transmission oil high temperature warning
- Headlight hi-beam indicator
- Electric backup alarm
- Engine temperature/oil pressure
- Engine protection warning system

Ottawa 60 DOT/EPA Certified

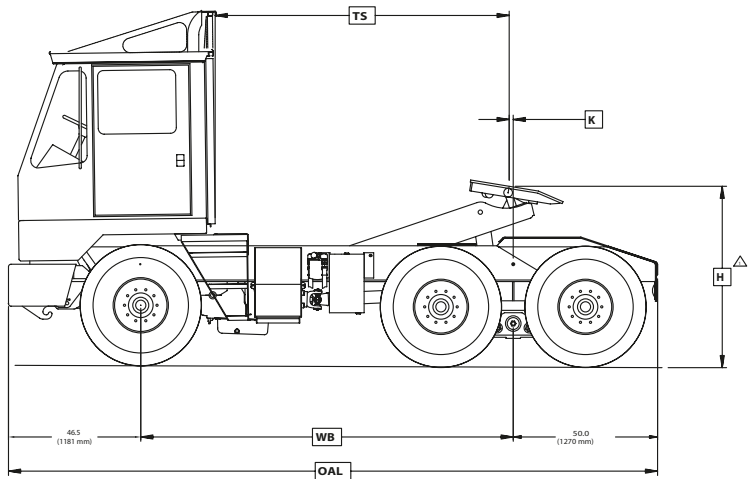
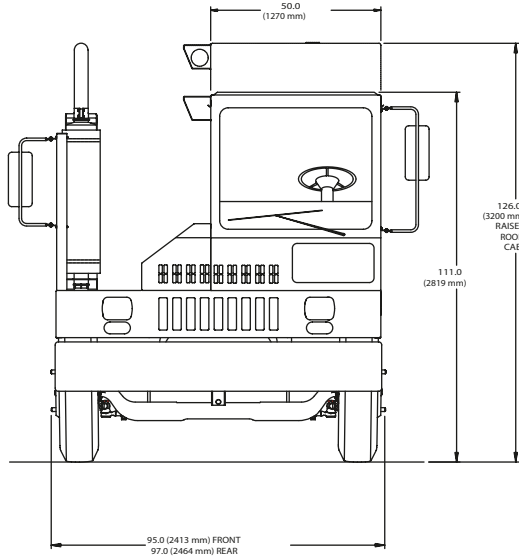

		BOOM POSITION	
WB	DIM	UP	DOWN
146" (3708.4 mm)	TS	113.8 (2763.5 mm)	117.9 (2867.6 mm)
	K	6.0 (152 mm)	1.9 (48 mm)
	H	65 (1651 mm)	48.0 (1219 mm)
	OAL	242.5 (6159.5 mm)	

HYDRAULIC SYSTEM

- 16 gallon tank with sight glass
- 10 GPM pump
- 5" hydraulic lift cylinders
- Hydraulic system fittings with "O" Ring
- Boom lift 17"

BRAKES

- Split Brake system
- FMVSS 121 Brake system with ABS
- Front: "S" Cam type 16.5" x 5" air actuated
- Rear: "S" Cam type 16.5" x 7" air actuated
- Automatic slack adjusters front and rear

FRAME FEATURES

- Welded 80,000 psi steel with 12" x 3 3/8" X 3/8" formed channel 43.25" wide frame with "L" frame reinforcement (3,878,000 in/lb RBM)
- 55° tapered deck curbside with reinforced removable bumper
- 50-gallon frame mounted round fuel tank, curbside
- Integral front and rear tow eyes

PNEUMATIC SYSTEM

- 15.2 CFM Wabco compressor with 3 tank air reservoir system total capacity 5688 cu. in
- Color-coded air lines

ELECTRICAL SYSTEM

- 12 Volt neg. ground with circuit breakers, 130-amp minimum charge alternator, color coded wiring in separate removable harness, 12-volt starter with positive engagement, two (2) 12-volt low maintenance batteries, cab dome light.

PAINT FINISH

- Cab: white DuPont Imron 5000
- Chassis and components powder coated primer, top coated with polyurethane, paint black
- Wheels: Paint "E" coat white
- Tectyl undercoating under cab and deck

